

Tool switch board  
Between P1.3 and P2.3  
there is a resistor  
mounted of 2k2ohm

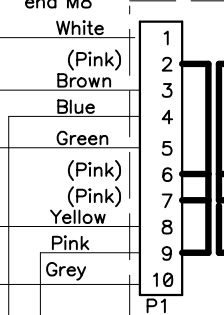

Optional chassi connector /  
Tool interface

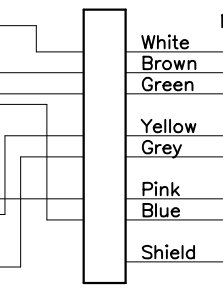

M12 Cable between liftsystem and tool

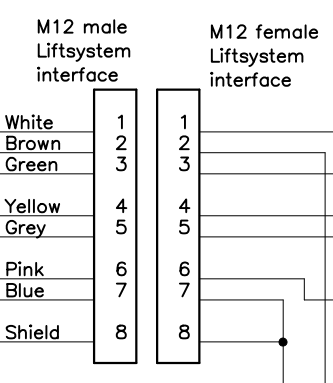

Brake coil or relay

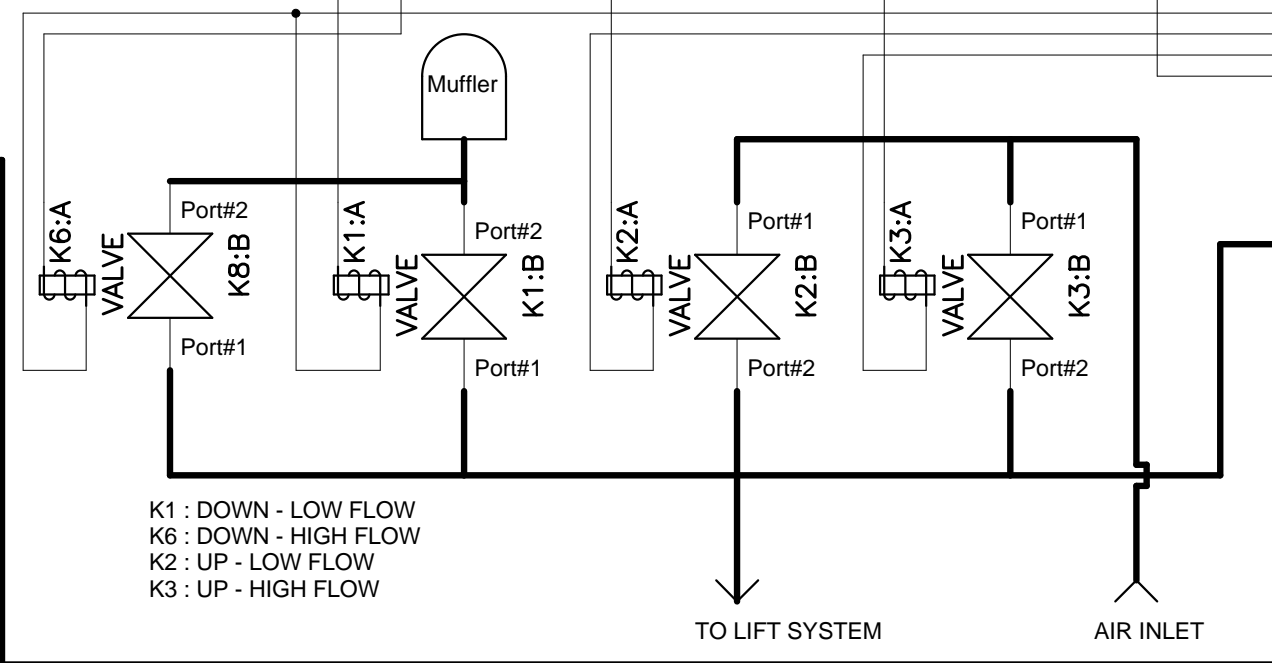
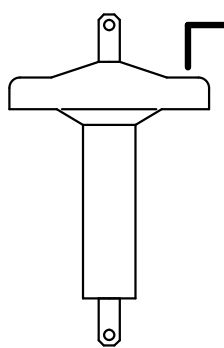
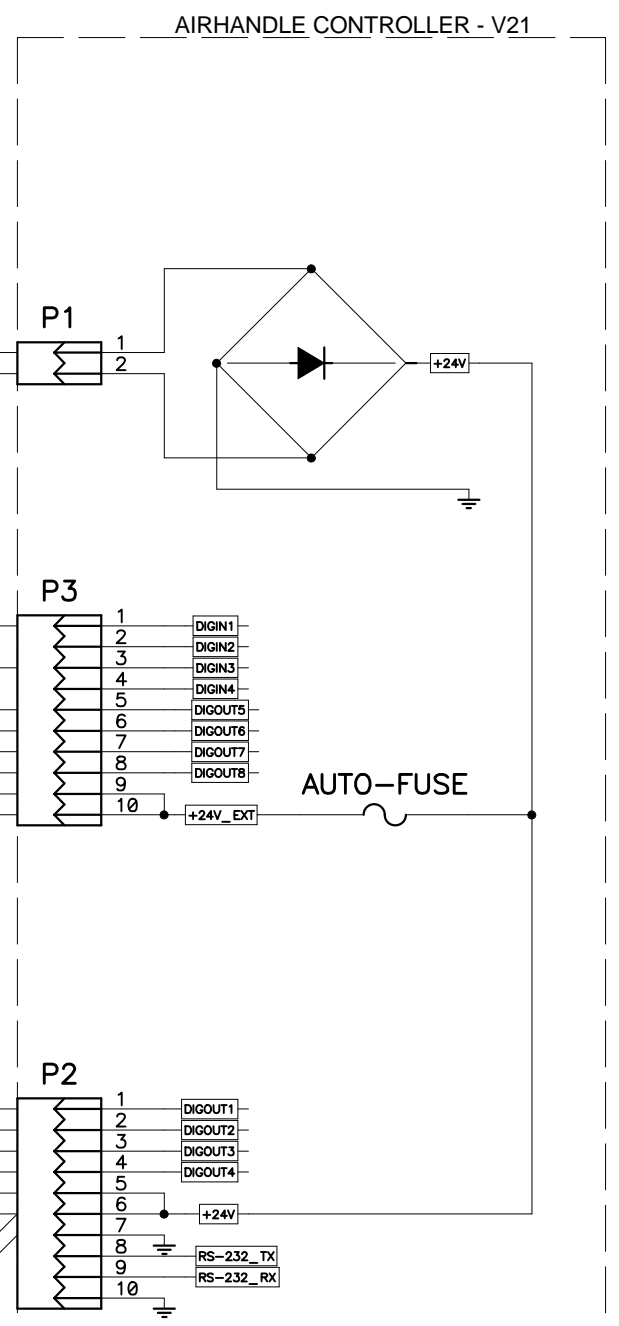

K1 : DOWN - LOW FLOW  
K6 : DOWN - HIGH FLOW  
K2 : UP - LOW FLOW  
K3 : UP - HIGH FLOW

Pressure sensor - 0..10 bar  
Pressure sensor - Airhandle

Title <b>Air Handle wiring – Noblock</b>		
Size <b>A3</b>	Number	Rev <b>P011</b>
Date <b>2012-01-15</b>	Drawn by CA/AH	
Filename <b>p011 wiring.sch</b>	Sheet 1 of 1	